



A.U.S. SPIELGERÄTE GMBH

SCHEYDGASSE 48, AT 1210 WIEN

+43 (0) 1 271 66 00 65 FAX +43 (0) 1 271 66 00 75

www.aus.at ✉ verkauf@aus.at



Installation manual Wurlitzer CD Conversion kit b

CD Kit Replacement of CD player types CDM3, CDM4 and CDM12 in
Wurlitzer Juke boxes

Replacement of CD player types CDM3, CDM4"s and CDM12 in Wurlitzer Juke boxes

Before ordering this conversion kit please check which S&CC unit and EPROM version is installed in your machine.

This can be achieved as follows.

1. Turn the Juke box power "ON"
2. Turn the "SERVICE" switch on the S&CC unit to the "ON" position. See Fig-7.
3. Press the 'LT" button on the S&CC unit. See Fig-7.
4. Press selection button 4 on selection keys.

The selection display will show the S&CC generation numbered followed by the Software version number.

On machines with generation-1 S&CC"s, the complete S&CC unit has to be changed.



This kit can be installed in WurlitzerJuke boxes currently operating with S&CC generation 2 units. Once you've identified your S&CC type as generation-2, you can proceed as follows.

1. Turn the "SERVICE" switch to the "OFF" position on the S&CC unit.
2. Press the 'LT" button on the S&CC unit.

The Juke box will return to its normal operating mode.

Please ensure that your Juke box is fitted with the new type CD gripper arm shown below before you start this conversion.

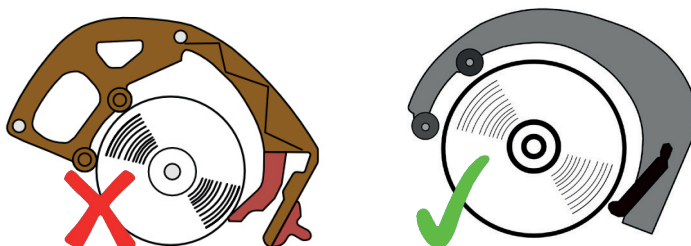

The following tools and parts should be available before starting this conversion.

Parts

- Main CD sledge.
- Sledge stop bracket.
- Sledge return spring.
- Communication cable
- Power cable.
- Eprom V3.09

Tools

- 7mm open ended spanner.
- Flat end or slotted terminal screw driver.
- Number one Philip screwdriver.
- Long nosed pliers.

Lets start the conversion and proceed as follows

1. Turn the Juke box off.
2. Remove the e-clip and shim washer from the clamp arm push rod, as shown in Fig-1, save parts.
3. Remove the e-clip and connecting bolt on the traction lever.
4. Remove the tension spring connecting the sledge to the chassis, save this Part.
5. Remove the old sledge stop bracket from the right side of the Wurlitzer chassis.

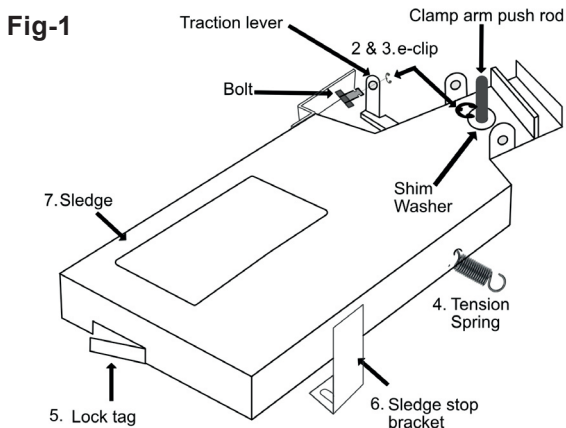

6. Lift the sledge up from the chassis so that you have access to all sledge cables.
7. Unplug all cables connected to the sledge.
8. Install the new sledge stop bracket with its fixing plate as shown in Fig-2.
9. If you are upgrading from a CDM3 or CDM4 then carry out sections 10 & 11, otherwise proceed to (section-12).

Fig-2

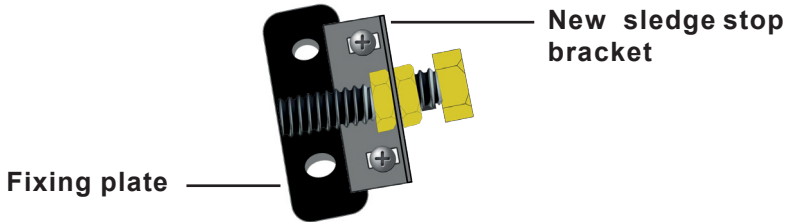

10. Disconnect all cables connecting the CD controller (see Fig-3) to the rest of the machine.
11. Remove all hardware associated with the CD controller from the machine, I.E. Brackets or plates associated with the CD controller's installation.

Fig-3

CD Controller

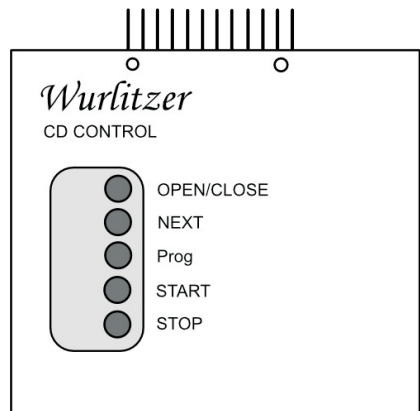

12. a. Connect the new 5-way comms cable to the new sledge. See Fig-4
Ensure the opposite end connects to P5 on the S&CC unit.
- b. Connect the existing audio lead to the new sledge sound board.
See Fig-4
- c. Connect the new power cable to the new sledge as shown in Fig-4
Please read (section-13) to identify a suitable power point connection in
your machine for the opposite end of the power cable.

Fig-4

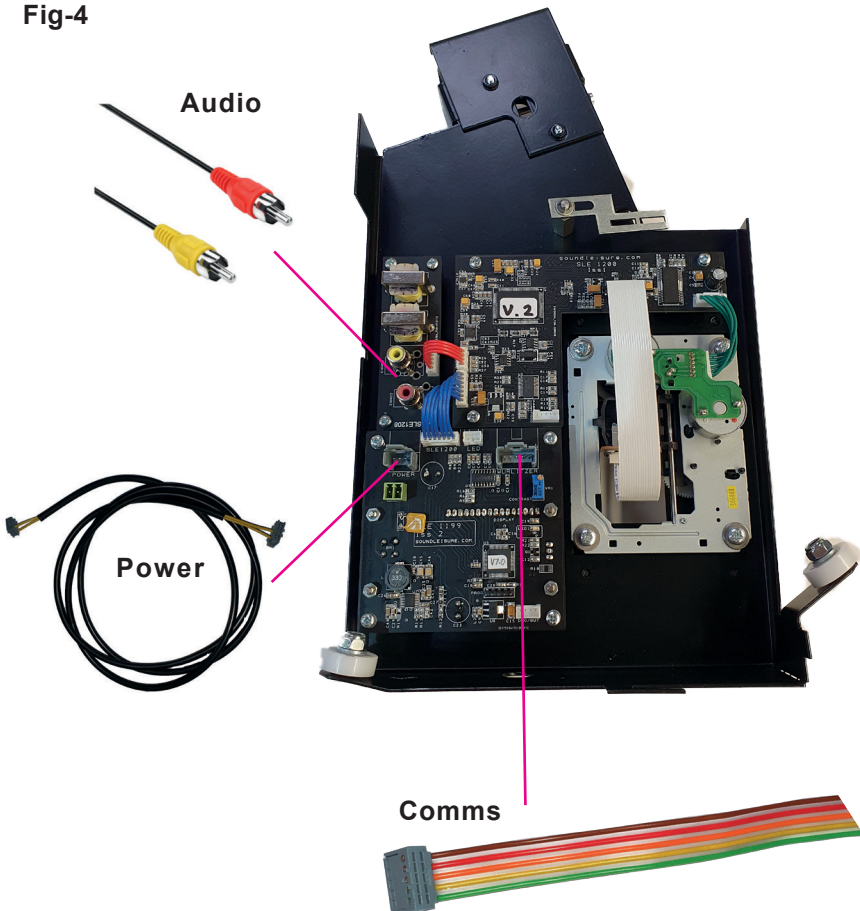

13. There are three potential power point connections for powering the new CD sledge.

This sledge system has been tested at +12VDC with a quiescent current of 165mA.

Maximum transient peak current of 350mA.

Ideal PSU required $12V \times 0.5A = 6W$

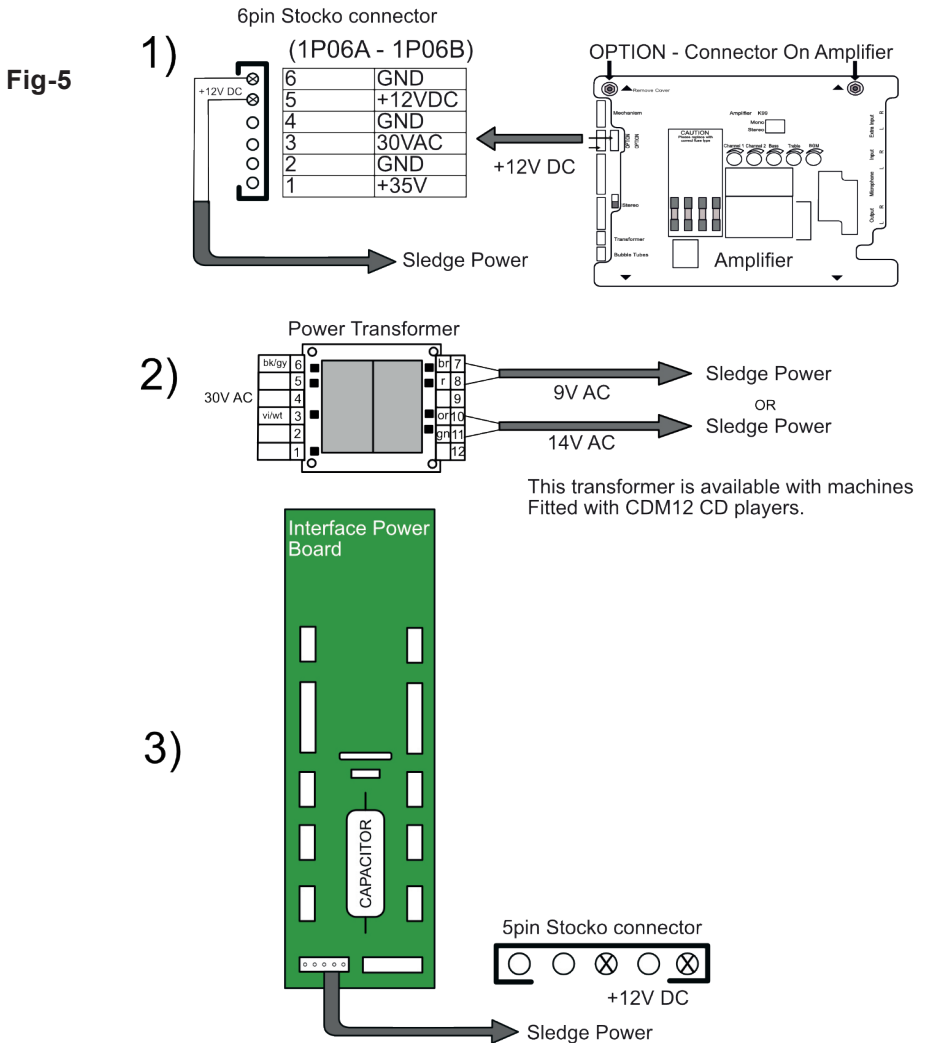

14. a. Position the new sledge over the clamp arm push rod and secure with shim washer and e-clip as shown in Fig-6.
- b. Bend the lock tag out at (45degrees) see Fig-6.

Fig-6

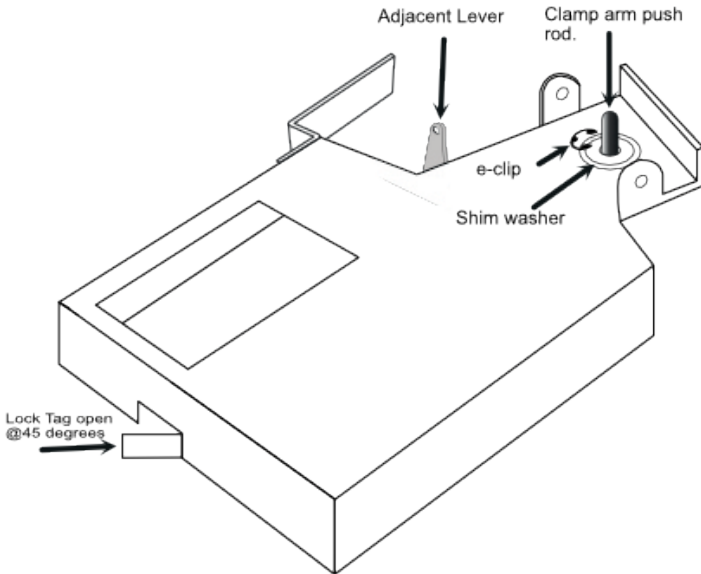

15. a. Remove the CD player lens protection cap if fitted.
16. a. Note the positions of the bonus wires on the S&CC unit shown in Fig-7 before removing them.
- b. Remove the front cover from the S&CC (Selection & Credit Computer) by unscrewing the four retaining nuts.

Fig-7

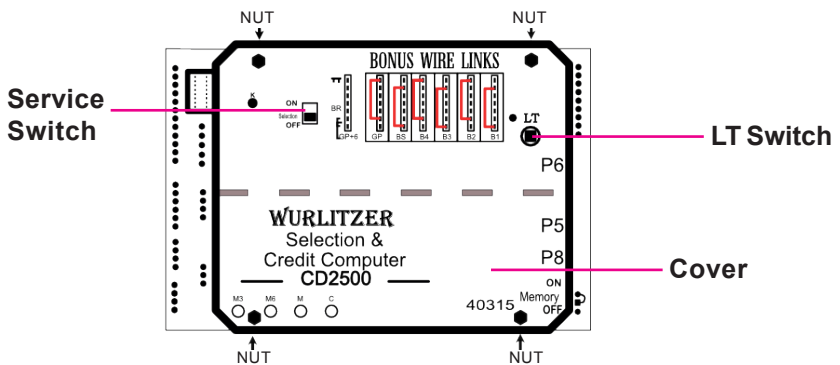

17. Replace the old Eprom IC22 in the S&CC unit, with the new Eprom V3.09 as shown in Fig-8.

Fig-8

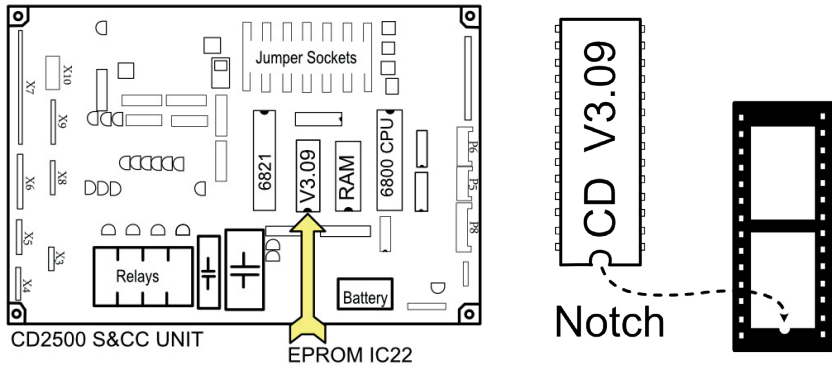

18. a. Reinstall the S&CC cover.
b. Reconnect any bonus wires that were removed before the cover was taken off.
c. Turn the power "ON" to the machine.
d. Set the service switch on the S&CC unit to the "ON" position.
e. Press the "LT" on the S&CC unit once.
f. Press and hold down selection button "3".
g. While holding down button 3 press the "R" button once.
h. Turn the service switch to the "OFF" position.
i. Press the "LT" button on the S&CC unit once.

Check that the gripper loads the CD onto the CD player correctly as follows

19. a. Select a track from any CD position via the selection keys.
- b. When the CD is about to land on the CD player as shown below in Fig-9, turn the gripper motor switch to the "OFF" position.
- c. Look over the CD centre to view the CD player turn table hub.
- d. The CD player hub should be positioned in the centre of the CD.
- e. If it's not then loosen both clamp arm lock screws "S" and the x,y axis Lock nuts.
- f. Adjust the "X" and "Y" axis adjustment bolts until alignment is achieved.
- g. Once the alignment is correct secure both clamp arm lock screws "S".
- h. Also, ensure both lock nuts are secure on the "X" and "Y" axis adjustment bolts.
- i. Lastly, make sure the gripper ON/OFF switch is returned to the "ON" position.

Fig-9

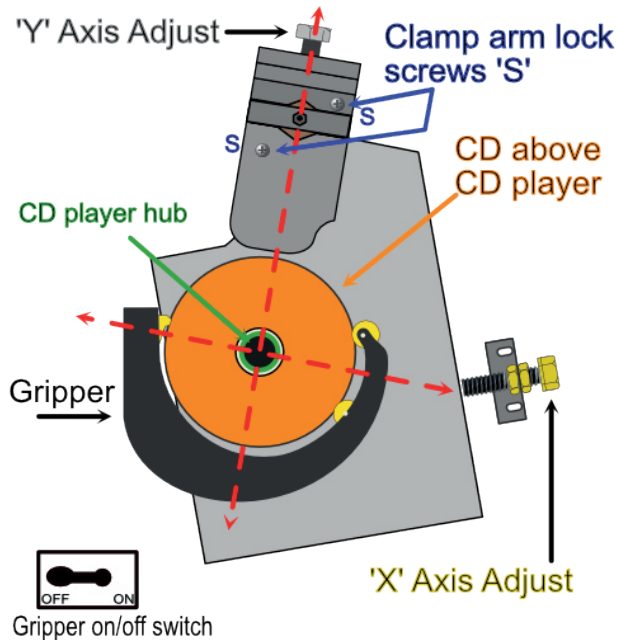

20. Mechanical Adjustments

This section deals with any minor mechanical adjustments you may need to make to the new sledge if necessary such as:-

Adjustment of clamp arm height if needed.

1. Make a selection.
2. With the CD on the turntable, adjust the clamp arm height with the clamp arm adjustment screw see Fig-10.
3. The clamp arm height should be set so that there is no more than 2mm of magnet showing between the CD top face and the magnet clamp head as shown in Fig-11.

Fig-10

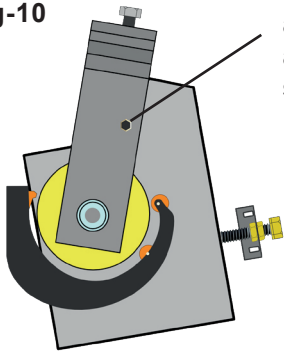

Clamp arm height adjustment screw

Fig-11

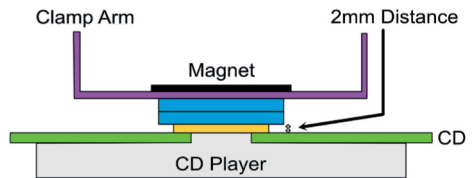

Aligning the sledge and gripper arm if needed

1. With the CD on the turntable and playing a track, adjust bracket "A" with a pair of pliers left or right until you have equal distance between the CD and the gripper arm as shown in Fig-12.

Fig-12

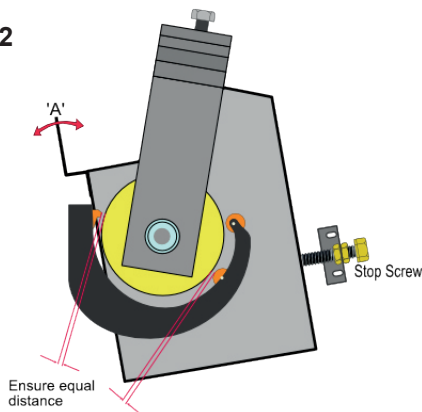

Setting the clamp arm height in the rest position

1. With no CD on the player make an adjustment to the hex cone see Fig-15 so that the clamp arm is in one of two positions depending upon the serial number of your machine see Fig-13 and Fig-14.

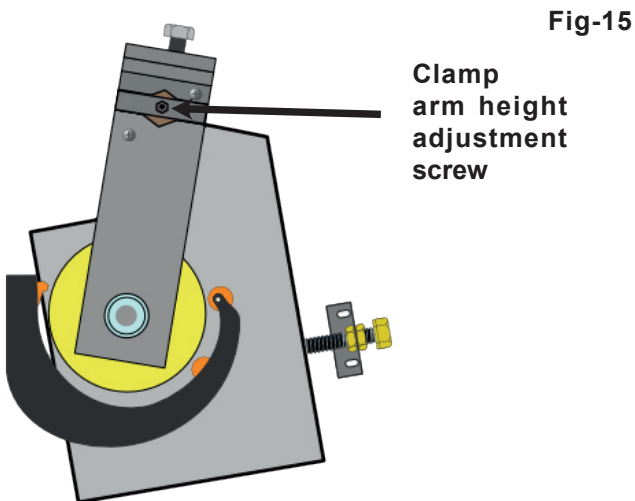
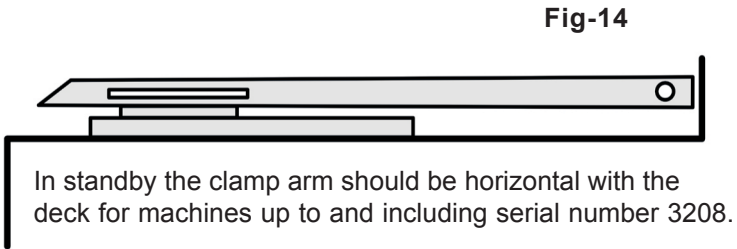
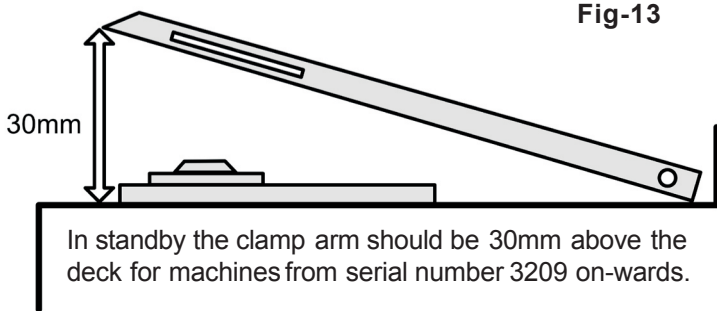

Notes:

1. When a CD fails to initialised, the display on the new sledge unit will respond with "BAD TOC or DISC". The CD will remain on the sledge unit until the S&CC unit issues a reject command to the sledge, this can take approximately 45 second. (TOC = Table Of Contents)
2. Please make sure you have read all the installation instructions as some minor adjustments may be necessary to the sledge metal work as listed in section-20 when installing this kit into your machine.
3. If you encounter any issues please contact your supplier.